

REVISIONS			
REV	DESCRIPTION	DATE	APPROVED

R 5 5/8

R 3 1/8

16° TYP

5.5° TYP

"K" DRILL (.281) THRU
82 DEG C-SINK TO 17/32 DIA

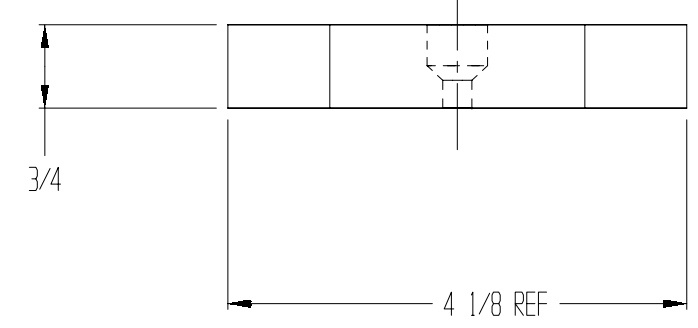
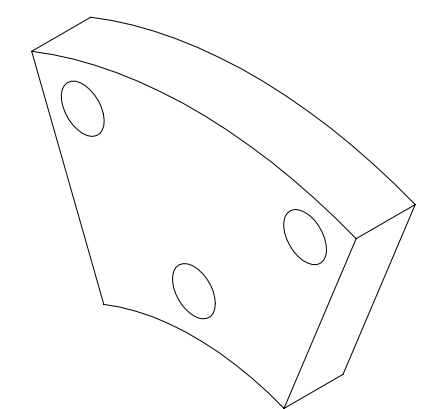

© SelectPart Incorporated, 2003. All Rights Reserved.
Any use of this drawing or the information contained herein for a purpose other than as expressly authorized by SelectPart Inc. is expressly prohibited.

UDS: .00 = +/- .010 UDS: .000 = +/- .001 UDS: .0000 = +/- .0005 UDS: DRAFT ANGLE= 3 DEGREES UDS: ANGLE= +/- 1/2 DEGREE UDS: FRACTIONAL= +/- 1/64 UDS: FINISH= AS SHOWN		 50 Hutcherson Drive Gorham, Maine 04038 USA / 207.854.3874	
PART DESCRIPTION: SELECTPART FRICTION PAD "K"			
DRAWN BY: MNL	SIZE: C	PRT NO: K-PAD	DWG NO: K-PAD
CHECKED BY:	SCALE: NONE	MATERIAL: VARIOUS	SHEET 1 OF 1
DATE: 6 FEB 03			